

Version 1.01

(10.03.2015)

## Installation instruction FISTUNE® DAB/DAB+ Integration

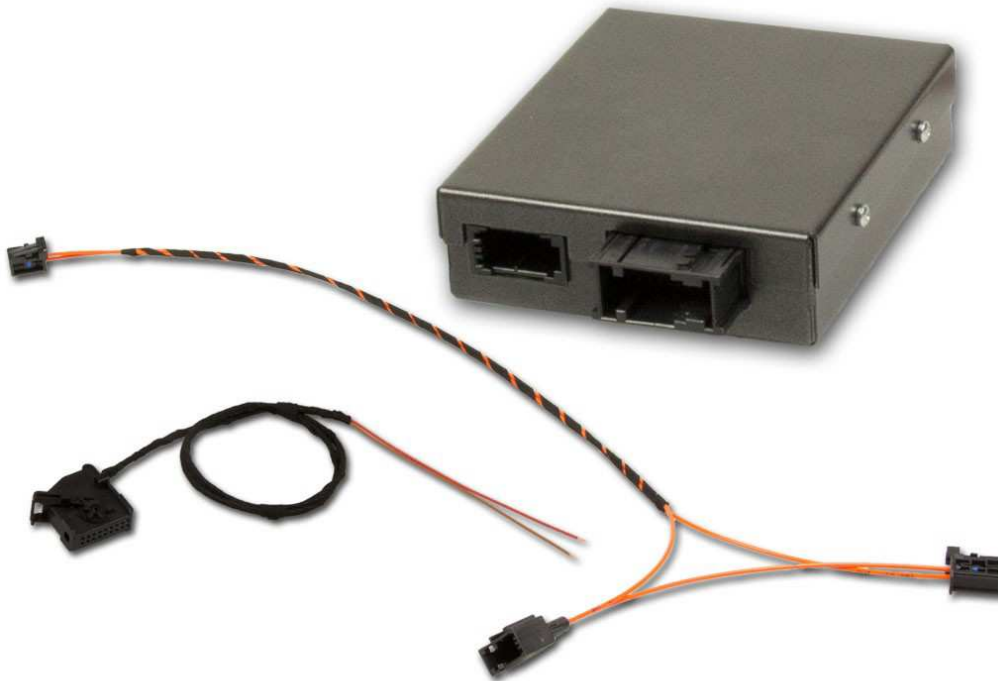

Article no. 40149 FISTUNE® DAB / DAB+ Integration BMW E-Series CIC

Article no. 40150 FISTUNE® DAB / DAB+ Integration BMW F-Series

### BMW E-Series/F-Series

---

## Contents

Disclaimer .....	2
Copyright .....	3
General advice .....	3
Safety instructions .....	4
References of legal regulations for operation.....	4
Notes .....	5
Scope of delivery for 40149, 40150.....	5
Installation instructions .....	6
Radio-/navigation unit dismantling if the vehicle is NOT equipped with components that are connected by LWL in the trunk .....	7
Interface connection .....	10
Coding dongle (only for vehicles <b>WITHOUT</b> CD-changer).....	12
Execution of the coding .....	12
Operation CIC.....	13

---

## Disclaimer

Dear Buyer,

our cable harnesses are developed with the help of the circuit diagrams and wiring schemes of the particular vehicle producer and they are tested and adjusted to the original vehicle before the serial production. Therefore the integration into to the on-board electric and electronic system follows the information of the vehicle producers. Our installation instructions are consistent, in course of the necessary pre-understanding and the precision of the presentation in text and picture, with the staff usual in vehicle electrics / electronic and they have proven their value already hundredfold in practice.

If during the installation of our products drench occur difficulties, so we are any time ready to provide you support by phone or E-Mail. Additionally we offer you to use the installation in our workshop in Bad Segeberg.

The costs arising from the third parties assigned with the installation of our products, bears the Buyer. Only when it proves that there is a failure of our product we will compensate the evidenced costs of the assembly and the costs of the dismantling of the defective product, whereby we limit the cost reimbursement up to 110 EURO gross and we reserve our right to check the claimed defect in our workshop in Bad Segeberg. The costs of dispatch will be refunded in case of a justified claim.

We made the experience that each professional workshop which is equipped with a necessary diagnosis devices, diagnosis software and the circuit diagrams of the producer, can find the possible defects in our products within a short period of time, so the assembly and disassembly including failure diagnosis, can take place in maximum 60 minutes.

We also made the experience that many workshops are not able to cope with the producer's circuit diagrams and cannot read the common wiring schemes, so for simplest installation labors several hours are calculated. You will understand that we neither take the risk to find a reliable workshop nor we finance the training for the workers of the workshop of your confidence.

The costs that arise from the acquisition of the missing parts or replace for defective parts from another suppliers, we reimburse to the amount of the costs which would have arisen in case of subsequent delivery (saved expenditure). In this case according to the legal warranty law there would be no reimbursement right of any kind, as long as no deadline was set for the supplementary performance or a deadline for supplementary performance has not expired.

So if you have any problems during the installation or operation of our products call us write us an E-Mail, send us the product or come to our workshop in Bad Segeberg with your vehicle. We are sure to find a solution for concern of every kind.

Kind regards

Your Kufatec GmbH & Co. KG Team

## Copyright

Our assembly and operation manuals, assembling diagrams and additional documentation in text or picture form are protected by law.

Disclosure and distribution of this documentation through print or online media is permitted only after previous written acceptance from Kufatec GmbH & Co. KG.

## General advice

While developing this product, your personal safety combined with the best operating service, modern design and an up-to-date production technique was especially taken into account.

Unfortunately, despite the utmost care injuries and/or damages might occur due to improper installation and/or use.

Therefore please read with great care and completely this operating manual and store it appropriately!

For your safety all our products pass through a 100% control check.

We reserve the right to carry out technical changes which serve the improvement at any time.

According to each article and purpose, it is sometimes necessary to check each country's legal regulations before installing and starting the unit.

In case of guarantee claims, the device has to be sent back to the seller in the original packaging with the attached bill of purchase and detailed defect's description. Please pay attention to the manufacturer's return requirements (RMA). The legal warranty directions are valid.

The warranty claims as well as the operating permissions become invalid due to:

- a) unauthorized changes to the device or accessories which have not been approved or carried out by the manufacturer or its partners*
- b) opening the device's frame*
- c) self-made repairs on the device*
- d) improper use / operation*
- e) brute force to the device (drop, willful damage, accident etc.)*

During installation, please pay attention to all safety relevant and legal directions.

The device has only to be installed by trained personnel or similarly qualified people.

**Please limit the failure search to ca. 0,5 hour for the mechanical resp. 1.0 hour for electric labors during the assembly or functioning problems.**

To avoid unnecessary additional expenses please send immediately an inquiry to our technical support using the Kufatec form (<http://www.kufatec.de/shop/de/infocenter/>).

Please provide always the following information:

- chassis number
- part number of the add-on kit
- exact description of the problem
- already executed labor

---

## Safety instructions

The installation can be executed only by trained qualified personnel. Before the installation disconnect the power supply. Therefore cut off the battery from the vehicle electric system, follow the manufacturer's specification.

- *Never use bolts, screws and other fastening elements from car's safety devices or steering wheel, brakes because it may influence your driving safety and cause accidents.*
- *Connect the device only to a 12V vehicle voltage with chassis ground to the car body. This unit cannot be used in large trucks or other vehicles which use a DC 24 V battery wiring system voltage.*
- *Avoid to install the device in places where it could hinder the safe driving or functional efficiency of the other units installed in the vehicle.*
- *This unit is only for the use with the following vehicles and model line; Only connections described within this instruction manual are allowed or required to use for installation.*
- *For damage impact caused by faulty installation, unsuitable connections or assembling in inappropriate vehicle types or models Kufatec GmbH &Co.KG assumes no liability.*
- *We advise you that these units process data out of the MOST protocol from the vehicle. During the assembly of this unit we as supplier have access to a specific model and we as producer don't know the overall system you work with.*
- *Especially in case of changes within the same model line and the same model year we don't guarantee the usability of our products. In case of the usability of our products with the manufacturer's changes Kufatec GmbH assumes no liability.*
- *Kufatec GmbH assumes no liability that the assembly of the unit described in this manual is approved according the warranty regulations of the single car manufacturers. Please check your manufacturer's conditions and warranty before you begin the installation.*
- *Kufatec GmbH reserves the right to change the device specification without further notice.*
- *Errors and changes excepted.*

## References of legal regulations for operation

Use this unit in the intended domain only.

If you use the unit in a foreign domain, if the unit is not installed properly, or if the unit will be reconstructed the operating permit and warranty will expire.

## Notes

**NOTE:** Applicable only from the BMW-software-version 2009 and for the following radio systems:

**Art.-no. 40149**

- CIC Professional
- CIC Business

**Art.-no. 40150**

- CIC Professional
- CIC Business
- CIC Radio

**NOTE:** Specific antenna module for BMW 5er Touring - F11

- **Article-no. 40147**

**Universal-Antenna:** DAB/DAB+ Antenna Interior Universal (article no. 39713)

**NOTE channel search:** There is no automatic channel search, it has to be done manually via MMI. A new manual channel search is necessary only for regional ensembles, when the vehicle changes the position and in this way the regional ensembles are altered too.

In case of national ensembles a new channel search is not necessary.

## Scope of delivery for 40149, 40150

- FISTUNE® Interface
- Cable set
- Coding dongle

## Installation instructions

The following presentation shows the laying of the wires and the position of the single components as well.

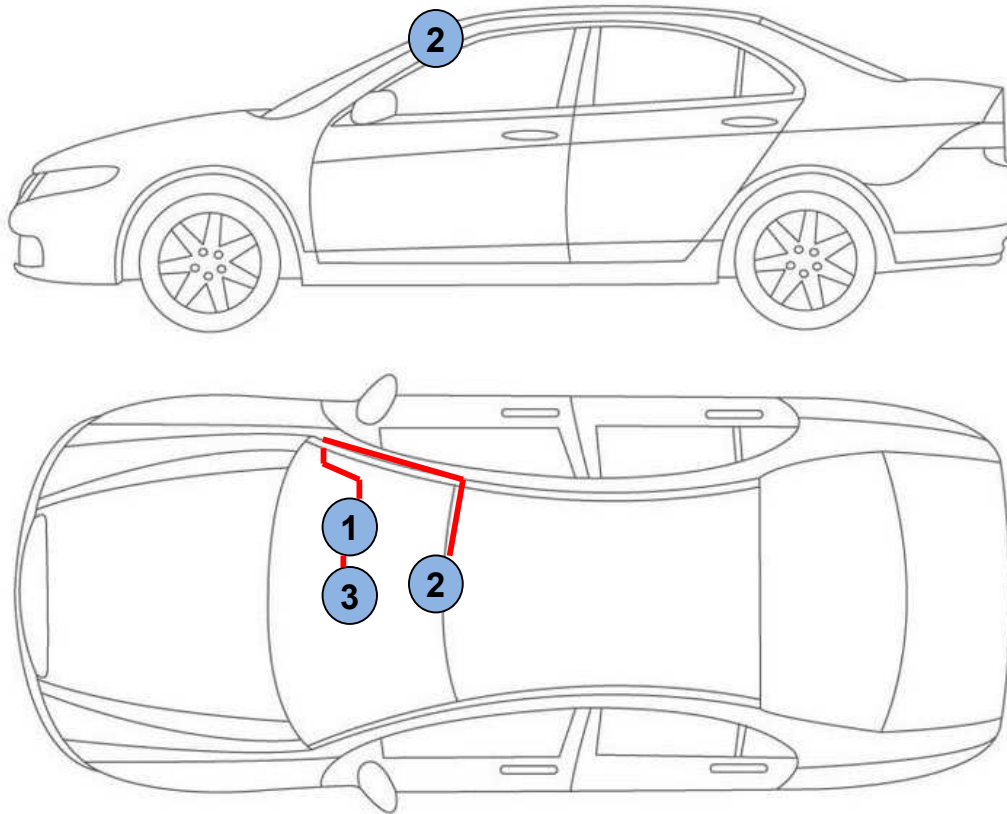

Scheme

- 1 – (Radio box) FISTUNE® Interface
- 2 – Antenna
- 3 – Radio unit

## Radio-/navigation unit dismantling if the vehicle is NOT equipped with components that are connected by LWL in the trunk

1er – E81, E82, E87, E88

Remove the blind using a suitable tool (plastic wedge – to avoid damage). This is only inserted – 5 fastening spots (fig. 1 and 2).



Fig. 1



Fig.2

Remove the air-conditioning control unit (fig.3). Take out the covering of the navigation computer (fig. 4). Loosen the necessary bolts of the radio resp. navigation computer (fig. 5). Carefully pull out the unit.



Fig.3



Fig.4



Fig.5



1er – F20

3er – F30

5er – F07, F10, F11

7er – F01

Dismantle the blind of the dashboard. The blind is fastened on 7 spots, fig. 6 and 7.



Fig.6



Fig. 7

Using a suitable tool (dismantling wedge – to avoid damage) carefully lever the blind out of the frame, fig. 8 and 9.



Fig. 8



Fig. 9

Loosen the screws of the front blind (air-conditioning control unit) – disconnect the original plug connections – take out the air-conditioning control unit, fig. 10 and 11.



Fig. 10



Fig. 11

Loosen the necessary screws of the radio-navigation unit – disconnect the original plug connections – carefully pull out the unit, fig. 12 and 13.



Fig. 12

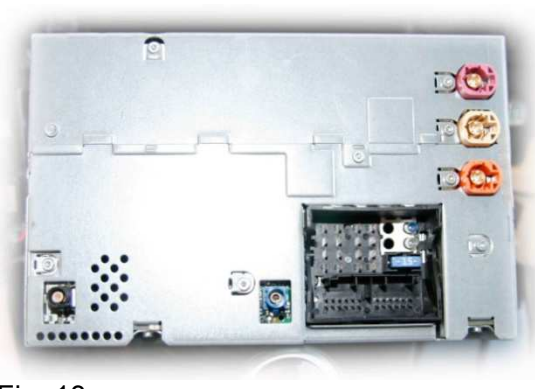

Fig. 13

Carefully lever the blind out of its frame using a suitable tool (dismantling wedge – to avoid damage), fig. 14 and 15.



Fig. 14



Fig. 15

Loosen the screws of the front blind, fig. 16. Loosen the necessary screws of the radio resp. navigation computer, fig. 27. Carefully pull out the unit.



Fig. 16



Fig. 17

## Interface connection

### Light conductor

Remove the original light conductor plug from the Quadlock plug, fig.18. Clip the delivered housing on the just removed (original) light conductor. Connect the original light conductor plug with the socket of the delivered cable set, fig. 19.

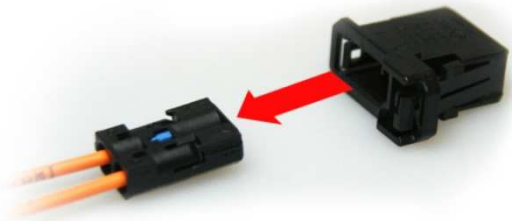

Fig. 18



Fig. 19

Connect the 18-pin and the light conductor plug to the interface – remove the blind plug from the interface, fig. 20 and 21 show the correct connection of the interface.

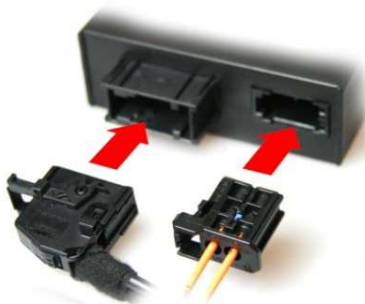

Fig. 20

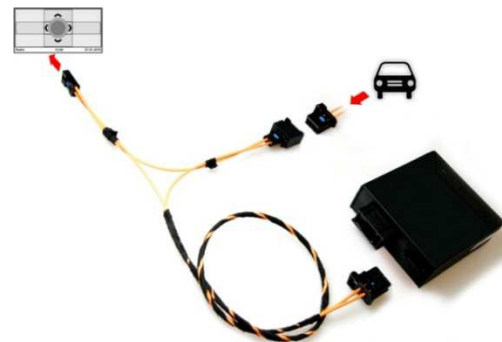

Fig.21

Finally integrate the light conductor in the Quadlock plug and connect this again in the radio/navigation unit.

Now proceed further with the above described sequence „Antennas“ and „Power supply“.

## Antennas

Then connect the antenna plug with the unit. For a high quality digital reception the connection can take place to the original BMW antenna system or one of the above mentioned antennas can be assembled.

In order to be able to guarantee a trouble-free reception the antenna should be installed in an appropriate distance to: - shielded glass surfaces/ car body / another parts – that influence the signal reception.

The antenna has to be placed vertically or horizontally. We recommend to carry out some tests in order to determine an ideal antenna position in the vehicle.

## Power supply

The wires **brown (ground)** and **RED (permanent positive)** have to be connected by means of a solder or a new crimp joint specific to the vehicle.

<b>Brown</b>	-	<b>Pin 12</b>
<b>Red</b>	-	<b>Pin 15</b>

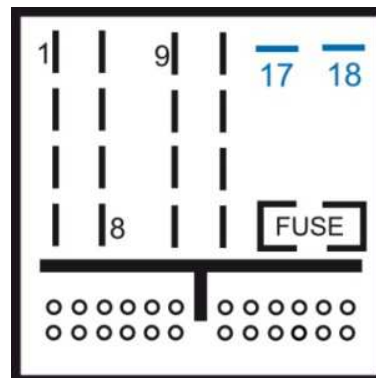
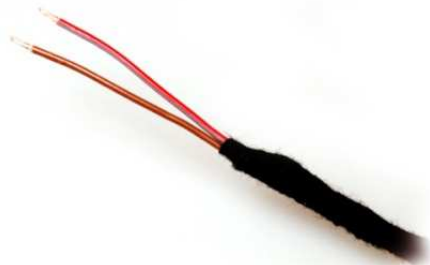

**CAUTION:**

**DO NOT use any press-on connectors!**

**NOTE:** The wire color can be also neutral (gray), therefore please consider the wire imprint!

## Coding dongle (only for vehicles **WITHOUT** CD-changer)

**NOTE:** This coding dongle is suitable only for the concluding coding if the retrofit of the FISTUNE®, article number 40149 or 40150 was conducted.

**NOTE:** The coding dongle is applicable **consistently for just one vehicle** only. It means during the first usage it stores the chassis frame number and another vehicle details.

The interface is equipped with an **LED** whereby the status of the diagnostics interface is indicated.

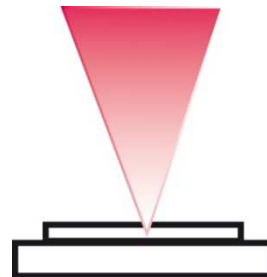

## Execution of the coding

1. Switch on the ignition, **THE ENGINE HAS TO BE SWITCHED OFF DURING THE PROGRAMMING**, wait ca. 1 minute and plug the interface in the diagnostics port (OBDII® plug) of the vehicle. This port is situated in the driver's foot space.
2. As soon as the coding has started the LED illuminates permanently.
3. After a short time the LED begins to flash fast.
4. After approx. 10-15 seconds the LED illuminates permanently again.
5. The dongle can be removed after the LED turns off.

**NOTE:** During the coding, the interface must not be removed from the diagnostics port! If the LED is still on after ca. 3 minutes, you can take out the interface again.

After the connection carry out sufficient function tests. If they are successful assemble everything in a backward sequence.

## Operation CIC

Because the FISTUNE® is fully integrated in the vehicle, all the information in your BMW Infotainment system is available for your. The operation of the digital radio reception takes place via the iDrive or the radio.

### Functions CIC

In order to enter the DAB-Menu, switch on the radio, press the „**MEDIA**“ button, fig. 22. Now if you want to run an automatic auto scan, scroll the list to the reception source „**DAB/DAB+**“, fig. 23, and start the „**Auto scan**“, fig. 24. It starts automatically. During the auto scan the display **99:44 > 99:00** appears.



Fig. 22



Fig. 23



Fig. 24

If the failure message **88:44 <> 88:00** appears, there is a problem with the reception. Check then all the connections, especially the antenna connection and start the search run again.