

Version 1.00

(29.01.2014)

Installation instruction FISTUNE® DAB / DAB+ Integration Audi MMI RMC

Article no.: 39818



Audi A3
Audi Q3

Contents

Disclaimer	2
Copyright.....	3
General advice	3
Safety instructions	4
References of legal regulations for operation	4
Notes.....	5
Scope of delivery for 39818	5
Installation instructions	6
Interface connection to the Main-Unit	7
Fig. 2.....	7
Coding.....	9
Operation	10

Disclaimer

Dear Buyer,

our cable harnesses are developed with the help of the circuit diagrams and wiring schemes of the particular vehicle producer and they are tested and adjusted to the original vehicle before the serial production. Therefore the integration into to the on-board electric and electronic system follows the information of the vehicle producers. Our installation instructions are consistent, in course of the necessary pre-understanding and the precision of the presentation in text and picture, with the staff usual in vehicle electrics / electronic and they have proven their value already hundredfold in practice.

If during the installation of our products drench occur difficulties, so we are any time ready to provide you support by phone or E-Mail. Additionally we offer you to use the installation in our workshop in Bad Segeberg.

The costs arising from the third parties assigned with the installation of our products, bears the Buyer. Only when it proves that there is a failure of our product we will compensate the evidenced costs of the assembly and the costs of the dismantling of the defective product, whereby we limit the cost reimbursement up to 110 EURO gross and we reserve our right to check the claimed defect in our workshop in Bad Segeberg. The costs of dispatch will be refunded in case of a justified claim.

We made the experience that each professional workshop which is equipped with a necessary diagnosis devices, diagnosis software and the circuit diagrams of the producer, can find the possible defects in our products within a short period of time, so the assembly and disassembly including failure diagnosis, can take place in maximum 60 minutes.

We also made the experience that many workshops are not able to cope with the producer's circuit diagrams and cannot read the common wiring schemes, so for simplest installation labors several hours are calculated. You will understand that we neither take the risk to find a reliable workshop nor we finance the training for the workers of the workshop of your confidence.

The costs that arise from the acquisition of the missing parts or replace for defective parts from another suppliers, we reimburse to the amount of the costs which would have arisen in case of subsequent delivery (saved expenditure). In this case according to the legal warranty law there would be no reimbursement right of any kind, as long as no deadline was set for the supplementary performance or a deadline for supplementary performance has not expired.

So if you have any problems during the installation or operation of our products call us write us an E-Mail, send us the product or come to our workshop in Bad Segeberg with your vehicle. We are sure to find a solution for concern of every kind.

Kind regards

Your Kufatec GmbH & Co. KG Team

Copyright

Our assembly and operation manuals, assembling diagrams and additional documentation in text or picture form are protected by law.

Disclosure and distribution of this documentation through print or online media is permitted only after previous written acceptance from Kufatec GmbH & Co. KG.

General advice

While developing this product, your personal safety combined with the best operating service, modern design and an up-to-date production technique was especially taken into account.

Unfortunately, despite the utmost care injuries and/or damages might occur due to improper installation and/or use.

Therefore please read with great care and completely this operating manual and store it appropriately!

For your safety all our products pass through a 100% control check.

We reserve the right to carry out technical changes which serve the improvement at any time.

According to each article and purpose, it is sometimes necessary to check each country's legal regulations before installing and starting the unit.

In case of guarantee claims, the device has to be sent back to the seller in the original packaging with the attached bill of purchase and detailed defect's description. Please pay attention to the manufacturer's return requirements (RMA). The legal warranty directions are valid.

The warranty claims as well as the operating permissions become invalid due to:

- a) unauthorized changes to the device or accessories which have not been approved or carried out by the manufacturer or its partners
- b) opening the device's frame
- c) self-made repairs on the device
- d) improper use / operation
- e) brute force to the device (drop, willful damage, accident etc.)

During installation, please pay attention to all safety relevant and legal directions.

The device has only to be installed by trained personnel or similarly qualified people.

Please limit the failure search to ca. 0,5 hour for the mechanical resp. 1.0 hour for electric labors during the assembly or functioning problems.

To avoid unnecessary additional expenses please send immediately an inquiry to our technical support using the Kufatec form (<http://www.kufatec.de/shop/de/infocenter/>).

Please provide always the following information:

- chassis number
- part number of the add-on kit
- exact description of the problem
- already executed labor

Safety instructions

The installation can be executed only by trained qualified personnel. Before the installation disconnect the power supply. Therefore cut off the battery from the vehicle electric system, follow the manufacturer's specification.

- *Never use bolts, screws and other fastening elements from car's safety devices or steering wheel, brakes because it may influence your driving safety and cause accidents.*
- *Connect the device only to a 12V vehicle voltage with chassis ground to the car body. This unit cannot be used in large trucks or other vehicles which use a DC 24 V battery wiring system voltage.*
- *Avoid to install the device in places where it could hinder the safe driving or functional efficiency of the other units installed in the vehicle.*
- *This unit is only for the use with the following vehicles and model line; Only connections described within this instruction manual are allowed or required to use for installation.*
- *For damage impact caused by faulty installation, unsuitable connections or assembling in inappropriate vehicle types or models Kufatec GmbH & Co.KG assumes no liability.*
- *We advise you that these units process data out of the MOST protocol from the vehicle. During the assembly of this unit we as supplier have access to a specific model and we as producer don't know the overall system you work with.*
- *Especially in case of changes within the same model line and the same model year we don't guarantee the usability of our products. In case of the usability of our products with the manufacturer's changes Kufatec GmbH assumes no liability.*
- *Kufatec GmbH assumes no liability that the assembly of the unit described in this manual is approved according the warranty regulations of the single car manufacturers. Please check your manufacturer's conditions and warranty before you begin the installation.*
- *Kufatec GmbH reserves the right to change the device specification without further notice.*
- *Errors and changes excepted.*

References of legal regulations for operation

Use this unit in the intended domain only.

If you use the unit in a foreign domain, if the unit is not installed properly, or if the unit will be reconstructed the operating permit and warranty will expire.

Notes

NOTE CHANNEL SEARCH: There is no automatic channel search, it has to be done manually via MMI. A new manual channel search is necessary only for regional ensembles, when the vehicle changes the position and in this way the regional ensembles are altered too.

In case of national ensembles a new channel search is not necessary.

NOTE antenna module: Depending on the vehicle type you need a different antenna module. This one has to be ordered separately. Following you will find a list of the modules:

- Audi A1 8X (article no. 39820, 39820-1)
- Audi A6 4G Limo (article no. 39528)
- Audi A6 4G Avant (article no. 39528-1)
- Audi A7 4G (article no. 39529)
- Audi Q3 8U (article no. 39821)

In all vehicle types additionally the article no. **39949** is necessary!

Universal-antenna: DAB+ active antenna universal for all vehicles (article no. 38234)

Scope of delivery for 39818

- FISTUNE® Interface
- Cable set

Installation instructions

The following presentation shows the laying of the wires and the position of the single components as well.

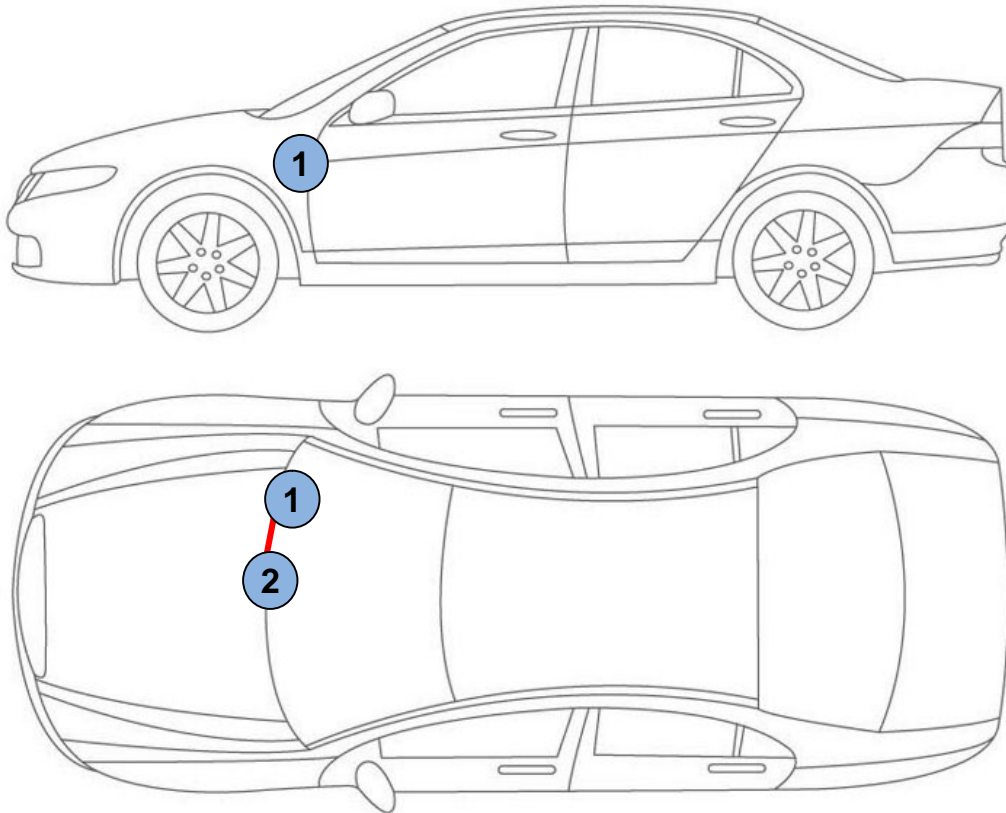

Scheme

1 – (Radio box) FISTUNE® Interface

2 – Main unit

NOTE: Place the FISTUNE® on a suitable spot behind the glove compartment. Consider the firm and safe seat of the box.

Interface connection to the Main-Unit

Light conductor

The connection takes place through Plug & Play on the back side of the main unit.

Remove the original light conductor plugs from the main unit. Connect the original light conductor plug with the socket of the delivered cable set (fig.1).

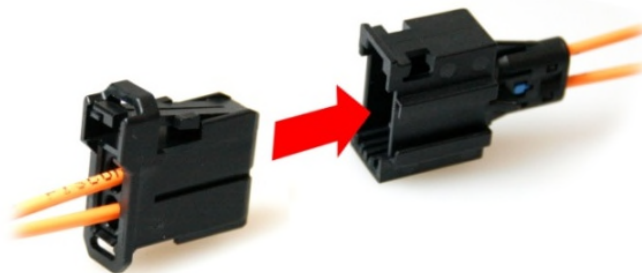

Fig. 1

Integrate the light conductor of the delivered cable set to the main unit. See the correct connection of the interface, fig. 2.

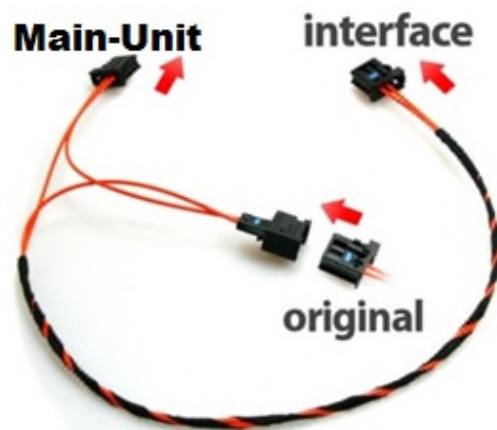

Fig. 2

Then connect the 18-pin plug and the light conductor to the interface, fig. 3.

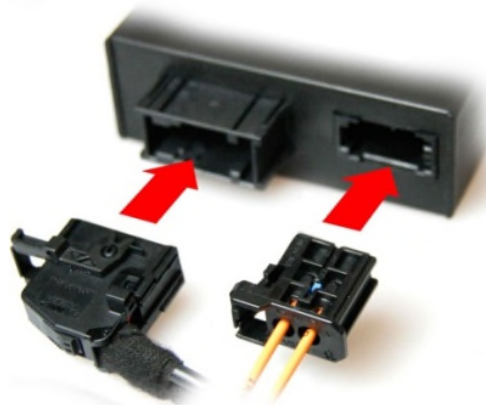

Fig. 3

Antennas

After that connect the antenna plug with the unit.

Power supply

The power supply takes place at the Quadlock-plug of the main unit. The wires **brown (ground)** and **RED (permanent positive)** have to be connected by means of a braze or new crimp joint specifically to the vehicle, fig. 4 and fig. 5.

Brown	-	Pin 17
Red	-	Pin 18

CAUTION: DO NOT use the press-on connectors!

NOTE: The wire color can also be neutral (gray), therefore consider the wire imprint!



Fig. 4

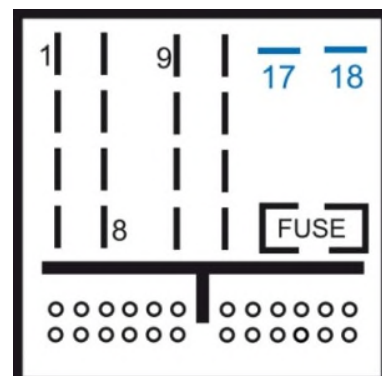

Fig. 5

After the connection carry out sufficient function test. If they are successful, then re-assemble everything in a backward sequence.

Coding

The coding of the vehicle after the assembly of FISTUNE® is not necessary. But you can add the module to the installation list under the address 19.

In order to execute the coding of the vehicle please contact your VW partner.

Address 19

Fahrzeug-Eigendiagnose	
Systemauswahl	
Wählen Sie ein System:	
Eigendiagnose ←	
Eigendiagnose - Verbundsysteme	
LT2 Eigendiagnose	
Crafter Eigendiagnose	
	

Self-diagnostics



Fahrzeug-Eigendiagnose	
Fahrzeugsystem auswählen	
55 - Leuchtweitenregulierung	
5C - Spurassistent	
16 - Lenkradelektronik	
46 - Zentralmodul Komfortsystem	
56 - Radio	
10 - Einparkhilfe II	
07 - Anzeige-/ Bedieneinheit	
17 - Schalttafeleinsatz	
37 - Navigation	
47 - Soundsystem	
77 - Telefon	
0E - Mediaplayer Position 1	
08 - Klima-/Heizungselektronik	
19 - Diagnoseinterface für Datenbus ←	
	

Address 19 Diagnostics interface for the data bus



Fahrzeug-Eigendiagnose	19 - Diagnoseinterface für Datenbus
Unterstützte Funktionen	Interfacebox Codierung 1 Betriebsnummer
Diagnosefunktion auswählen	
001 - Identifikation (Dienst \$1A)	
004 - Fehlerspeicherinhalt	
008 - Codierung (Dienst \$) ←	
011 - Messwerte	
014 - Lange Anpassung	
015 - Zugriffsberechtigung	
017 - Sicherheit	
022 - Ausgabe beenden	
Alle Diagnosefunktionen anzeigen	
	

Coding



Fahrzeug-Eigendiagnose	19 - Diagnoseinterface für Datenbus
Unterstützte Funktionen	Interfacebox Codierung 1 Betriebsnummer
Diagnosefunktion auswählen	
008.01 - Codierung	
008.02 - Codierung Verbauliste ←	
	

Installation list



Now include the encoding "0E" in the installation list.

Operation

Because the FISTUNE® is completely integrated in the vehicle, therefore the operation of the digital radio reception takes place by your MMI.

In order to reach the DAB-Menu, switch the radio on, press the knob „**MEDIA**“ and go for **Source** (key on the right near the TEL). If you want now to execute an automatic auto-scan, so choose the „**DAB/DAB+**“ reception source from the list and start the „**Auto-scan**“. This starts automatically. The following display appears during the auto-scan: **99:44 > 99:00**.



Fig. 6



Fig. 7

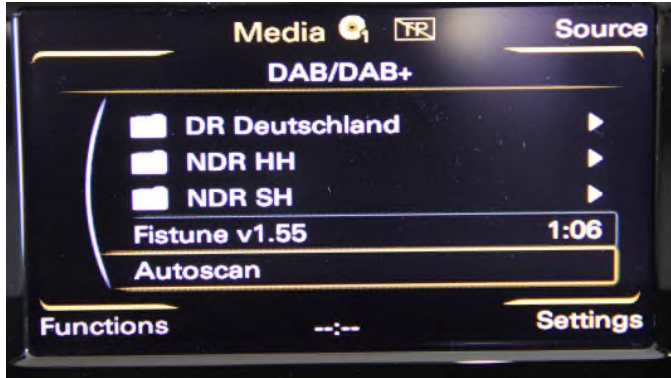

Fig. 8



Fig. 9

If a failure message **88:44 <> 88:00** appears, so there is a problem with the reception. Then check all connections, especially the antenna connection and start the search anew.

The operation is explained here on the basis of the device in Audi Q3, the operation in other Audi-devices is identical.